

So you want to make a book?



By Emilee Taxman

## **Table of Contents:**

Making a Custom Font (pps: 1-5)

Image and Text Transfers (from printouts onto the page) (pps: 6-14)

Bindings (pps: 7-24)

Common supplies list (pp: 16)

## Making a Custom Font:

You can make a custom font using a number of websites, but one of the most reliable is <https://www.calligraphr.com>.

Start by making an account.

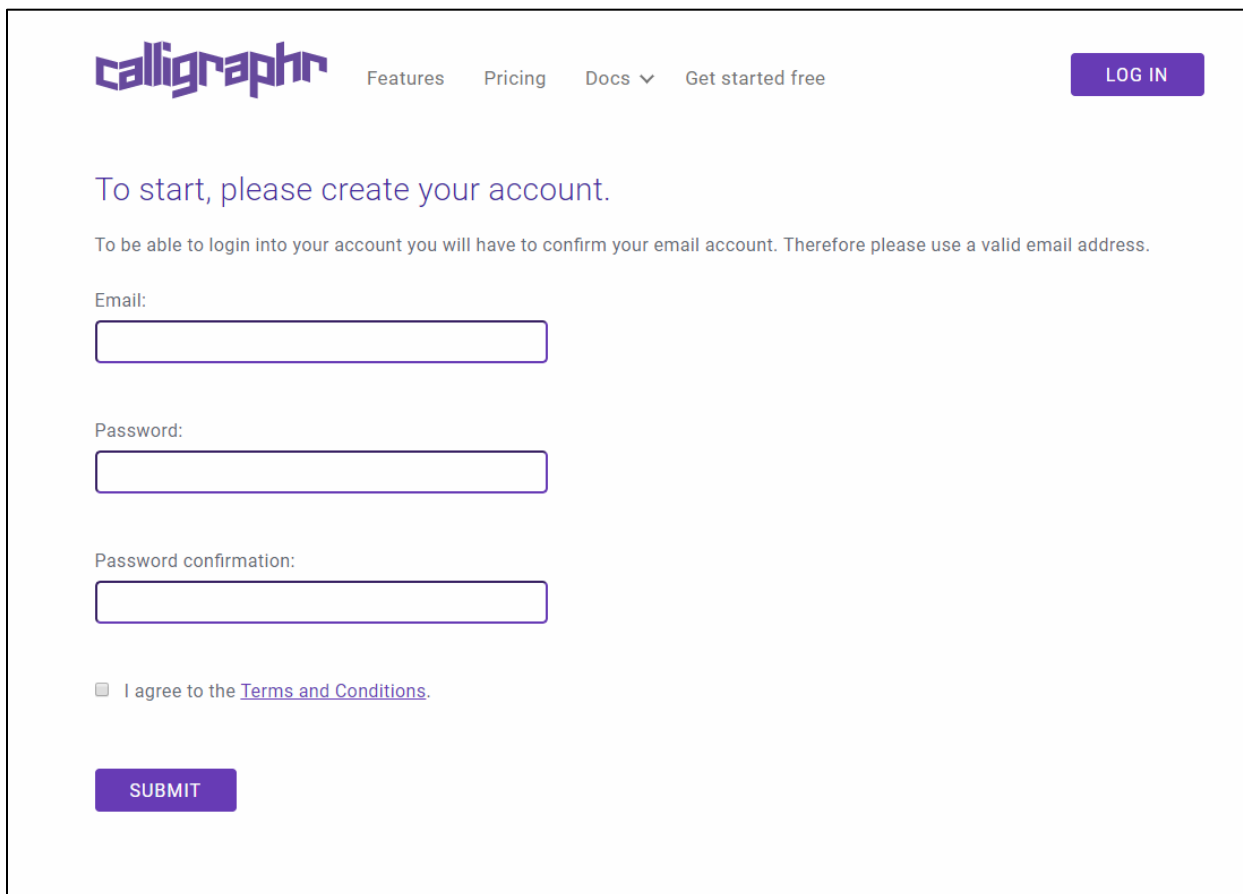

The screenshot shows the account creation page for Calligraphr. At the top left is the Calligraphr logo. To its right are navigation links: 'Features', 'Pricing', 'Docs' with a dropdown arrow, and 'Get started free'. In the top right corner is a purple 'LOG IN' button. The main heading reads 'To start, please create your account.' Below this is a note: 'To be able to login into your account you will have to confirm your email account. Therefore please use a valid email address.' The form consists of three input fields: 'Email:', 'Password:', and 'Password confirmation:'. Below the fields is a checkbox labeled 'I agree to the Terms and Conditions.' At the bottom left is a purple 'SUBMIT' button.

Once you've gone through and confirmed it via email, you'll end up at this screen:

TEMPLATES MY FONTS an@gmail.com Log out

# Calligraphr

Your first steps:

1. [Create a template](#) and print it out.
2. Fill it out.
3. Use a scanner, digital camera or a smartphone to capture your filled-out template.
4. On the [fonts page](#), choose the **'Inked template'** option and upload your image file.
5. Finally, click on **'Build font'** and enjoy your font!

You are logged in as emilee.taxman@gmail.com.  
[Log out](#) | [Edit Profile](#)

### Current plan

You are using the **free** version.  
[Upgrade your account to the Pro version.](#)

### Limits

One font  
75 characters (no ligatures) per font.  
2 variants per character .

Just follow the steps, starting with a template such as this one:

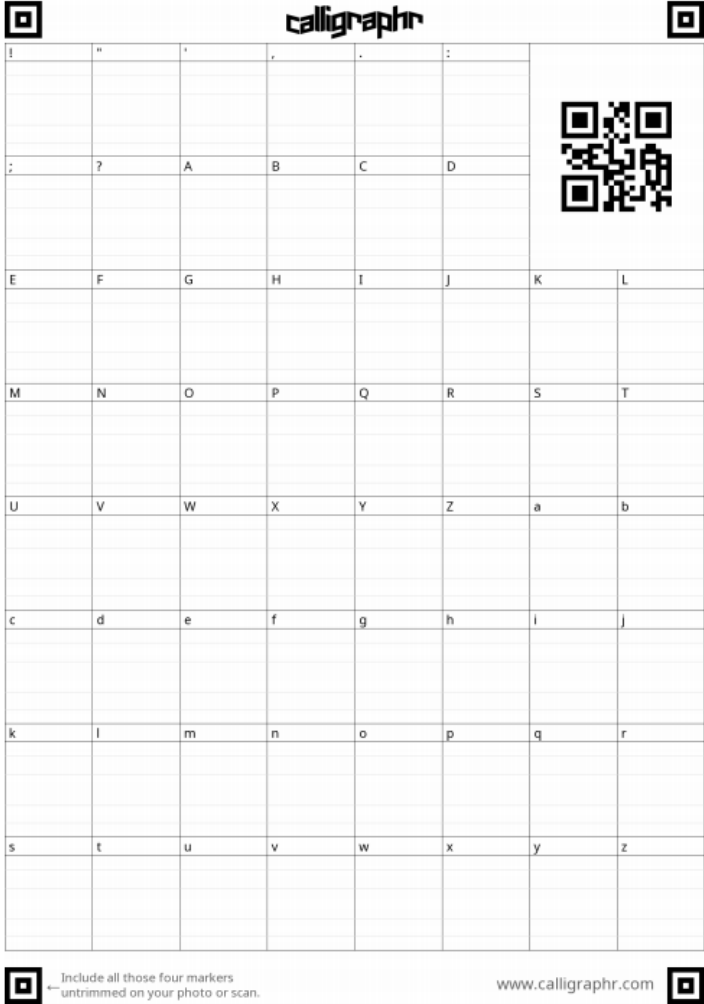

Print it out, fill in the letters within the boxes, then scan it in or take a photo.

Once you upload a scan or photo, you'll get a screen such as this one.

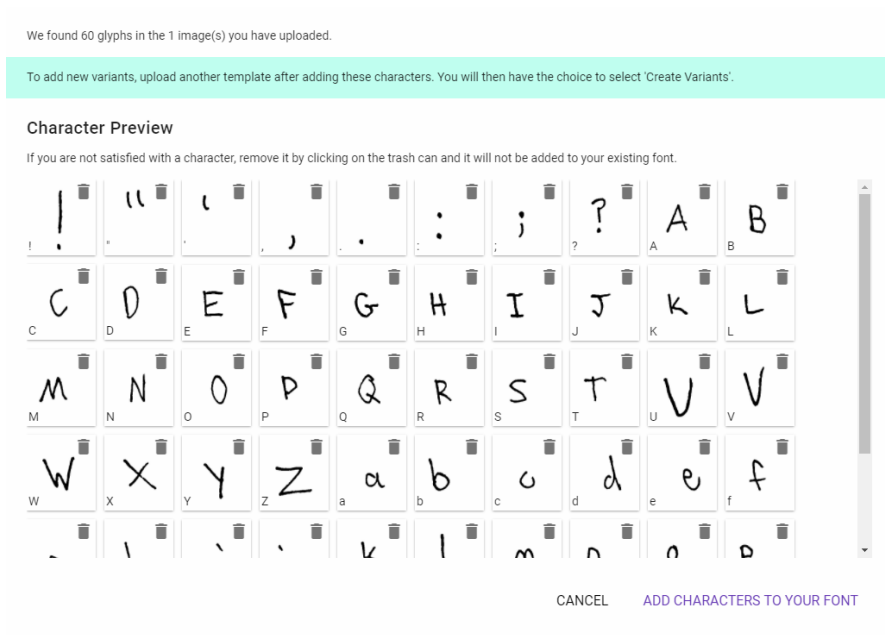

Click “Add characters to your font”, then when you’re ready, click build font and name it.

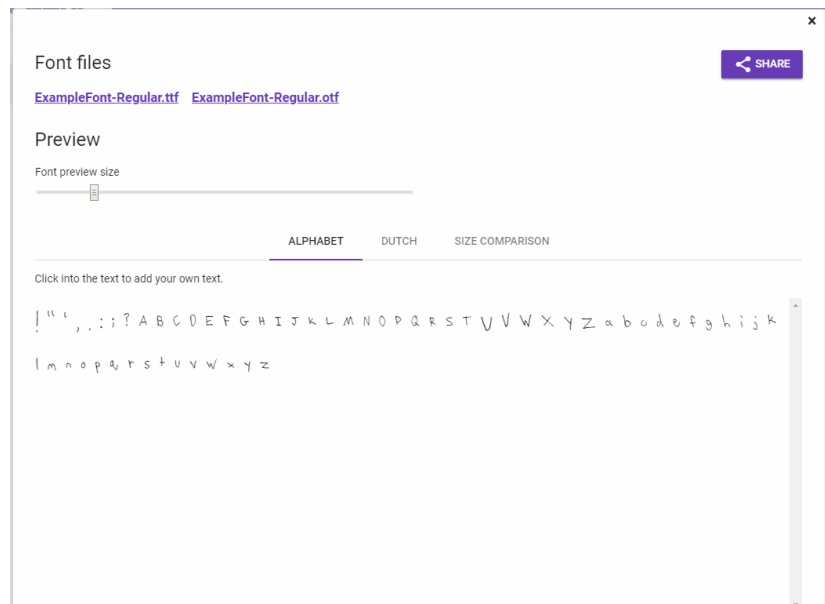

Next, download the file as a ttf by clicking on the link under “Font Files”. Click on the download then you should be prompted to install the font. Congrats! Now you’ve got your very own font.

It should automatically show up in programs like Word, Photoshop, and InDesign (pretty much anything that has a ton of fonts).

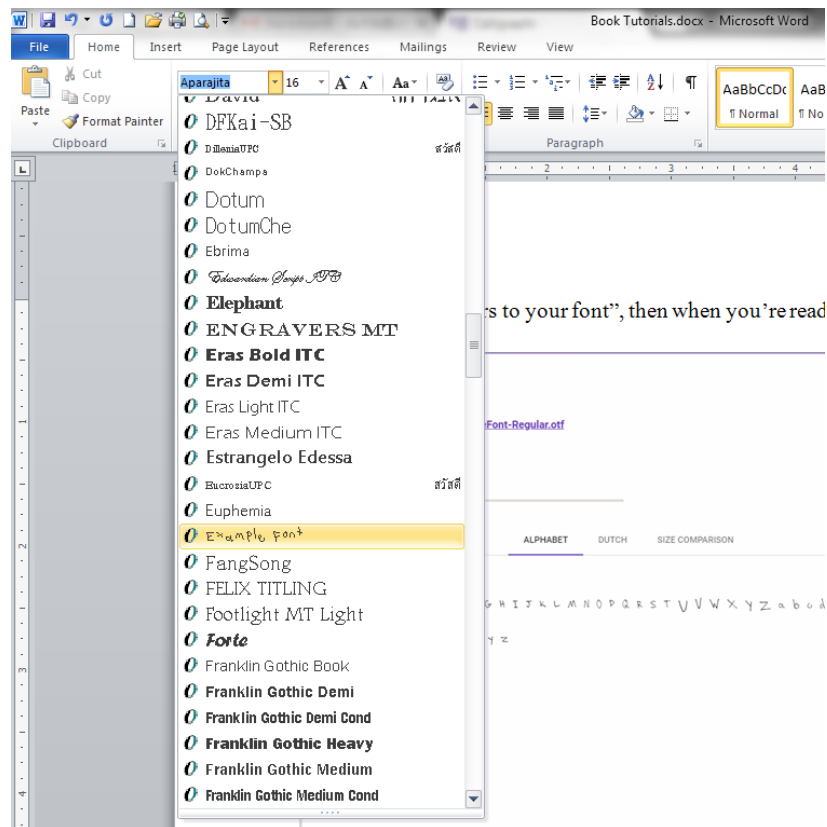

Now have fun with your font, and I’d recommend adding some extra stuff like numbers, and centering your letters along the right lines in the template so that they all show up as the same size.

## Image and Text Transfers

So now you've got your fancy font, or maybe you just want to get a normal font from your computer onto your page. You can always print it, but there's another option if you're putting it on the back of something delicate, want to put it at a bunch of weird angles or over itself, want only part of an image, or want a handmade feel!

There are a few methods, but all of them start the same way.

The first step is to print out whatever you're trying to transfer reversed. You can flip it easily using Photoshop, Illustrator, InDesign, or any other Adobe product (installed on all the Oberlin Mac Lab computers).





Next, you turn the paper upside down so the ink is touching the page that you want to transfer it onto. Apply the transferring method (in this case, a transfer/blending pen) on whatever you want to transfer.

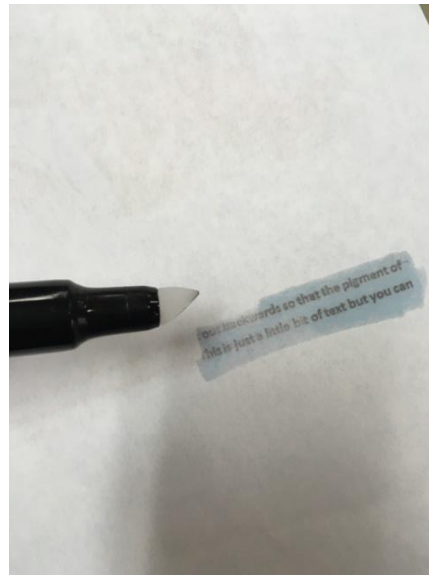
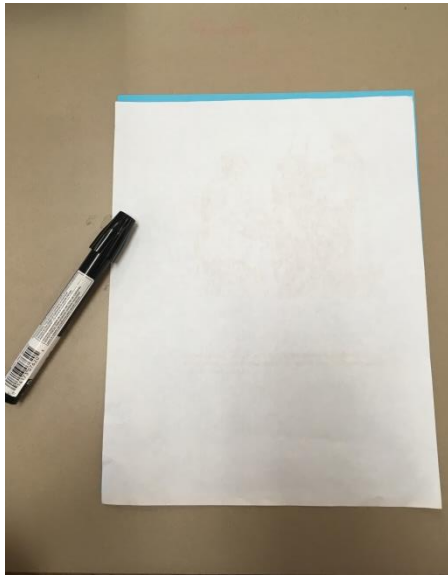

You then immediately go over the area that you just applied the transferring method to with pencil (before the transfer liquid dries). You will have to do a small section at a time, rather than covering everything with the transfer liquid and trying to do it all at once.

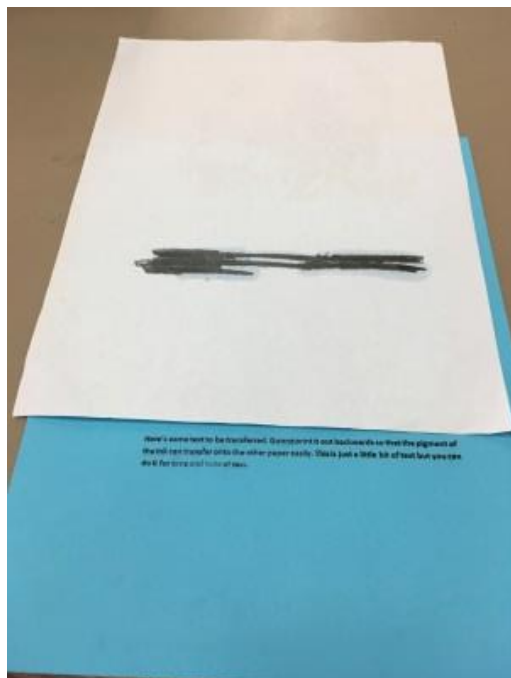

When the transfer is finished, you should have your text and/or image on the page!

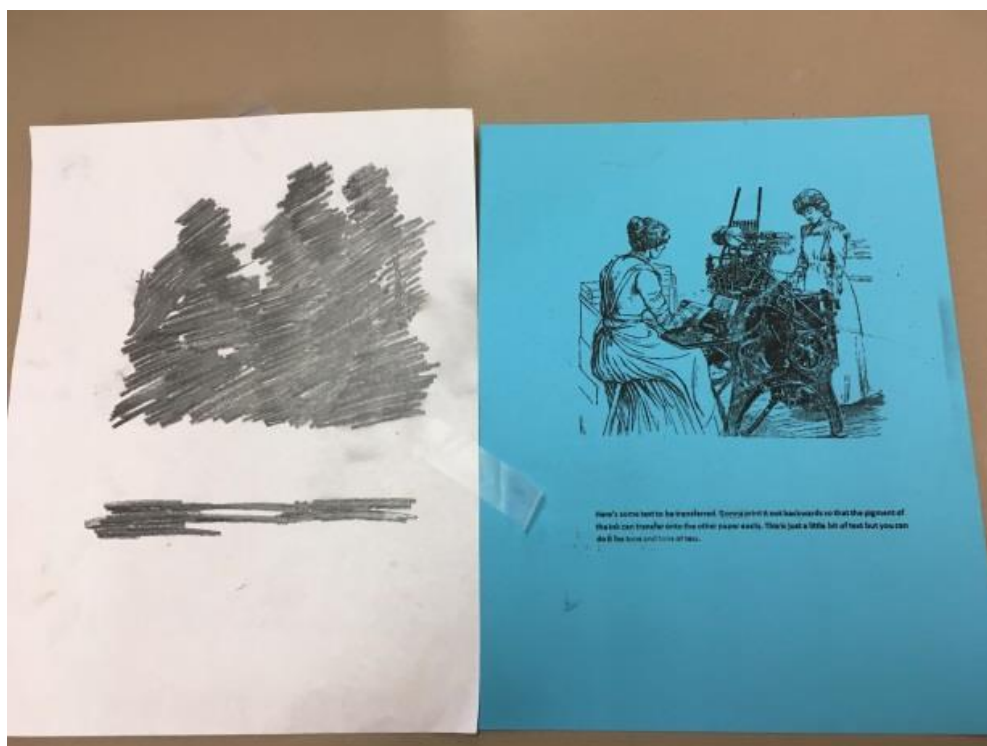

You can even transfer images in color!



Here are a few transferring methods:

### Transfer/Blending Pens



Transfer pens are a portable and easy option when doing image or text transfers. They're not super expensive (\$3-4 each). Unlike some of the others, there's no risk of spills and they're not too messy. The transfers that they do also tend to come out very crisp and clean (see above). The downsides are the fumes, which can be overwhelming, and that the process is a little slower since the pens aren't that big.

My recommendation: chartpak blender markers

<https://www.nordisco.com/products/chartpak-blender-marker-p-0-ad-marker->

[blender?gclid=EAIaIQobChMIIs63OmryU2gIVWrXACH1KFg76EAQYAiABEgKEffD\\_BwE](https://www.nordisco.com/products/chartpak-blender-marker-p-0-ad-marker-blender?gclid=EAIaIQobChMIIs63OmryU2gIVWrXACH1KFg76EAQYAiABEgKEffD_BwE)

## Wintergreen Oil



It's one of the most expensive methods (\$10-20), but the one bottle will last you a long time if you use it well. Also, bonus, it makes everything you make smell nice and minty, and no fumes to make you lightheaded. You do have to be careful, however, since the oil can stain if you get it on the wrong page. To use it, get a Q-tip and dip it in. Spread the oil across your page before putting the pencil over the text.

Recommendation:

<https://www.ebay.com/i/122663235887?chn=ps&dispItem=1>

## Acetone



This is absolutely the cheapest option, since acetone (aka nail polish remover) is everywhere. It can get as cheap as a dollar. These transfers can sometimes be a bit less sharp and the fumes can also start to hurt your head, but it's easy to get and easy to spread everywhere on the page. You should also use a Q-tip for this one.

## Bindings:

Well, now you've got some fonts and text and images, but you may find yourself saying "Hey, that's not a book! Isn't this supposed to be a book tutorial?". Well I have some good news, there are some easy way to turn those into a book: bindings!

There are all sorts of book bindings! Sewn, folded, glued! They range in difficulty quite significantly.

I'm going to provide a couple options for how to get started. The first is to get books from the Art Library! We have quite a few books on binding, almost all around the Z270-271 area. Here are some possible ones:

- "Japanese Bookbinding" (Z270 .J3 I3713 1986)
- "Handmade Books" (Z271 .B6 1997)
- "Creating Handmade Books" (Z271 .G62 1998)
- "Making Handmade Books" (Z271 .G625 2010)
- "The Art and Craft of Handmade Books" (Z271 .L43 2001)
- "Cover to Cover" (Z271 .L44 1995)
- "Basic Bookbinding" (Z271 .L593 1957)
- "The Penland Book of Handmade Books" (Z271 .P45 2004)
- "How to Make Books" (Z271 .S63 2007)
- "Binding for Book Artists" (Z271 .S665 1998)

## Common bookbinding supplies:

- Awl
- Bone folder
- Glue (many types, including mod podge and Yes paste)
- Thread (depending on the binding)
- Fun patterned papers
- X-acto knives
- A cutting mat

(Most, if not all of these, can be bought at Ginko Gallery)



I will have some tutorials for some of the more basic ones here. First off:

### Accordion Fold Binding:



This type of book is very simple in concept. It just involves taking paper and folding it in order to make multiple pages. It can either be made by folding one really long piece of paper, or by taking multiple pieces of paper and gluing them together.

With this binding, it's incredibly important to have your entire book planned out ahead of time (unless you plan to glue more on), since it will all be on one sheet of paper.

For a fancier look, these books can also be bound together at one edge to create a more traditional book structure. To do that, you would have to make covers, glue the ends of the accordion to them, and then attach the covers to each other.

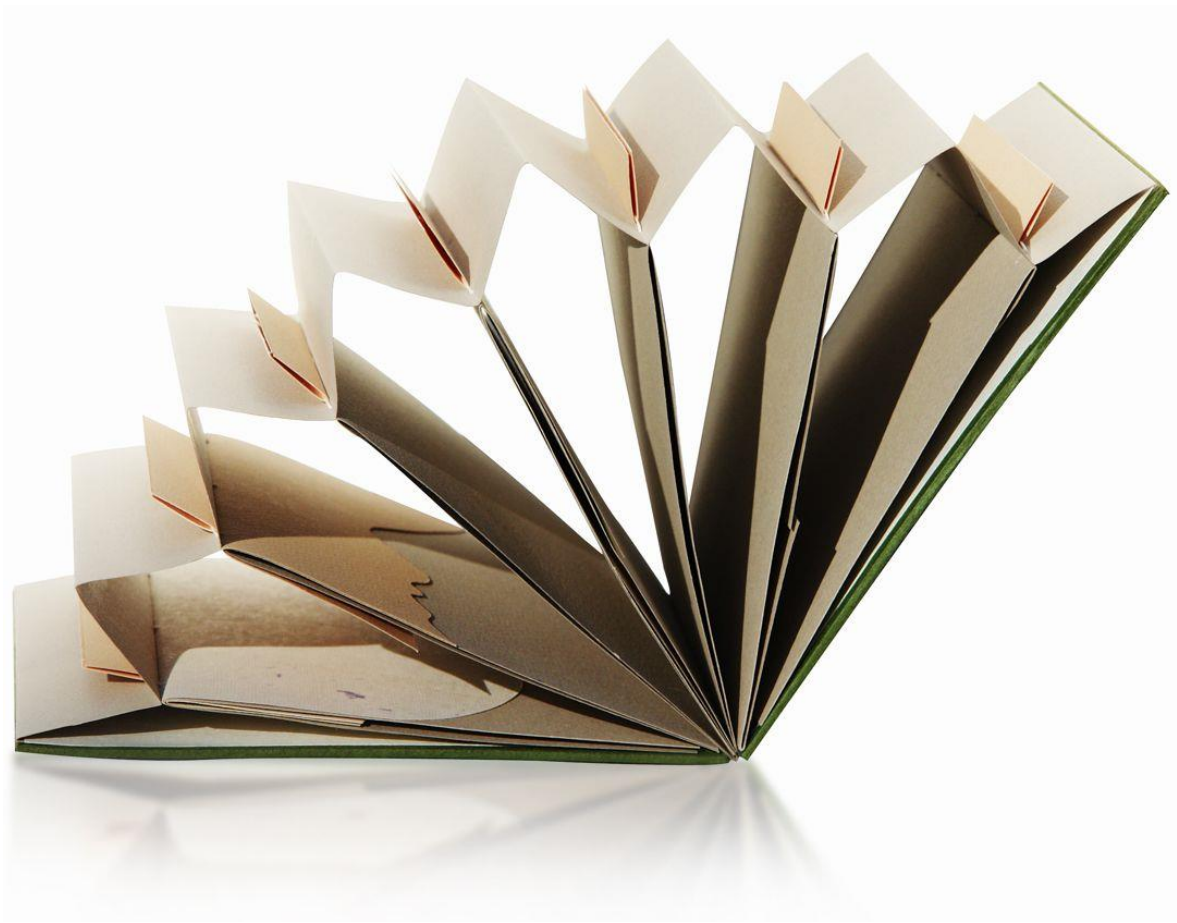

Here is a quick tutorial. Other ones can be found online or on YouTube by searching “accordion binding”

<http://www.designsponge.com/2013/03/bookbinding-101-accordion-book.html>

## Japanese Stab Binding

This binding is a little bit more complex than the last, and does involve sewing, but they can look very pretty when they're done. The level of complexity can also be determined by the artist.

For example, this is a very complicated one:



Whereas this one is more simple:



The binding may seem complex at first, but when you get the process down, it's pretty easy.

Step 1: Gather your pages and covers, then poke the desired number of holes (for beginners, I'd suggest 3-5). I would recommend making the holes an even distance apart, unless you want an uneven look. The holes can be closer to the edges than each other, though.

These holes can be done with a drill or with a tool called an awl. The awl is probably the easiest.

Step 2:

Thread the needle through the bottom hole, then loop it around the bottom to go into the same hole. Repeat but looping around the side. You should end up on the underside.

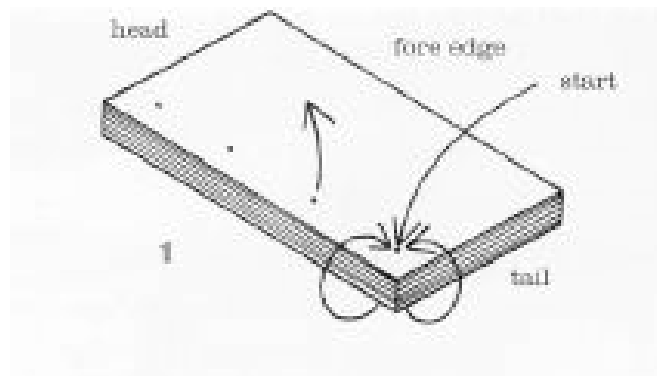

### Step 3:

Sew underneath to the next hole. Loop around to the side again. Repeat until you're at the last hole. The thread between the holes should alternate being above and being below.

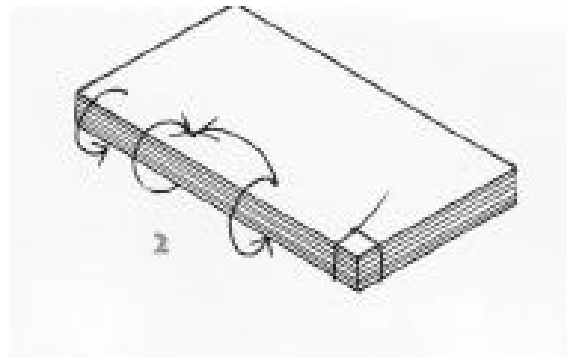

### Step 4:

When you reach the end, loop around in the same way you did at the other edge, then go back around to the other end, alternating the opposite way as before. When you reach the very end, tie the end of the thread onto the other thread.

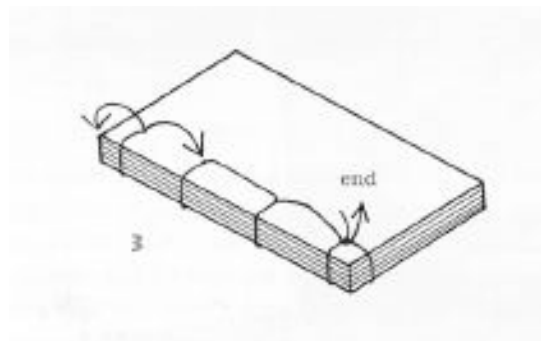

Congrats! The book should be bound.

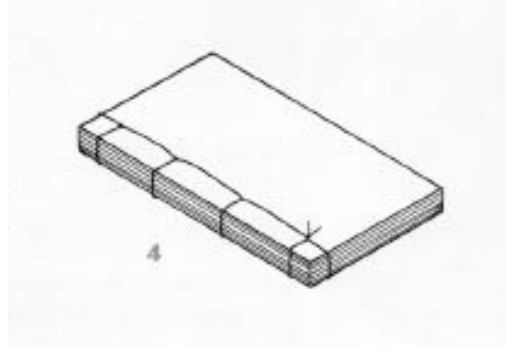

Here are a couple different tutorials:

Just a warning, some tutorials will start from a different hole, but the basic process is the same.

This one I think is the funniest:

<https://www.westdean.org.uk/study/school-of-conservation/blog/books-and-library-materials/intro-to-binding-japanese-stab-binding-tutorial-flexible-cover-with-three-hole-stitching>

This one is very detailed:

<https://crafts.tutsplus.com/tutorials/bookbinding-fundamentals-basic-stab-binding--craft-10250>

## X Book

The accordion binding is folded. No sewing is involved. This book is one that is often colloquially referred to as a zine binding. It makes an easy 8 page book!

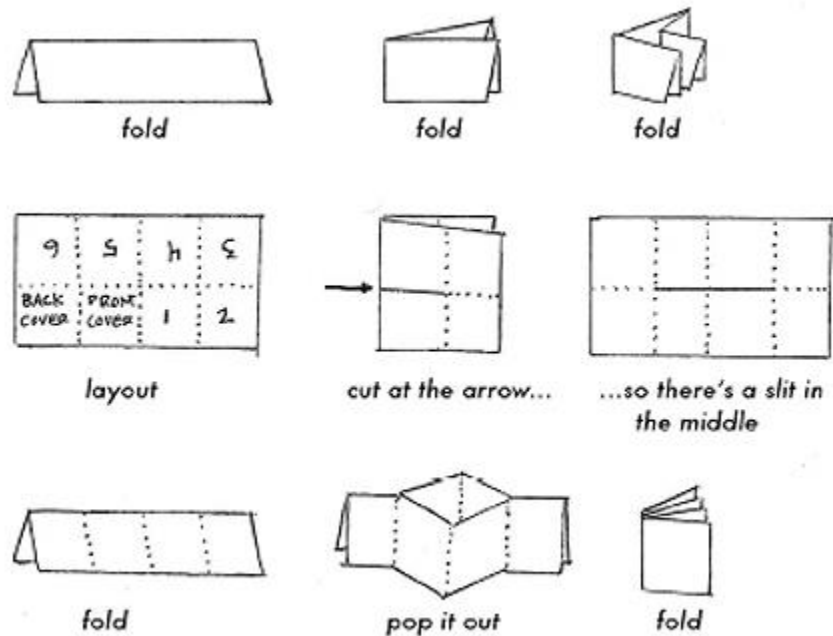

This graphic pretty much tells it all. Fold it longwise, then short wise, then short wise again. Then you should cut in the middle and “pop it out”. Then you should have a small folded book!

Here’s a tutorial for this one:

<http://experimentwithnature.com/03-found/experiment-with-paper-how-to-make-a-one-page-zine/>

Some other simple bindings you can look at:

- Five-hole pamphlet stitch (very simple):

<http://www.designsponge.com/2013/03/bookbinding-101-five-hole-pamphlet-stitch.html>

- Stick Binding

<http://gomakesomething.com/ht/decos/stick-bindings/>

- Perfect Binding (note: not actually perfect, just uses a lot of glue)

<https://www.lifewire.com/what-is-perfect-binding-1077757>

- Coptic binding (not actually simple but things look really nice when you do the binding right)

<http://www.tortagialla.com/2010/08/16/chain-or-coptic-stitch-bookbinding-tutorial/>



Thank you for reading! I hope you make some really cool books!

Also, if you have any more questions, please email  
[dartlib@oberlin.edu](mailto:dartlib@oberlin.edu)